

Industrial high bay projector

PREMIUM LUX 90LED VISIBLE

PREMIUM LUX 90 LED VISIBLE 6500K



About the product

The product Premium Lux LED is designed for general indoor lighting for rooms or protected spaces with medium height. That offers to the customers all the benefits of lighting with LEDs from a trusted manufacturer - quality light, longer lifetime and the decrease of power consumption and maintenance.

On the same time, that offers important advantages for the installation personnel, which does not need to open the luminaire.



EN 60598	RoHS	IP43		-20°C ÷ +35°C	103W LED
----------	------	------	---	---------------	----------

Application

Indoor lighting for rooms or protected spaces with medium height (up to 6-8m): industrial plants, sport halls, commercial spaces, petrol stations, and so on.

Light sources

- Power LEDs: white colour temperature cool-white 6500K, CRI ≥ 70 , which ensures a wide light distribution.
- On request the product could be equipped with LEDs with colour temperature neutral-white 3700-5000K or warm-white 2700-3700K.
- The use of LEDs ensures a long lifetime L70B50, of over 50.000 hours at $T_a=25^{\circ}\text{C}$, and a reduced power consumption.
- The LED system included in the product could replace or is equivalent with projectors with: high pressure metal halide lamps (HIE, HIT) 100W (variant 90 LED).

Advantages

High quality light. There are not necessary interventions for lamp replacements during exploitation.
Environment friendly.

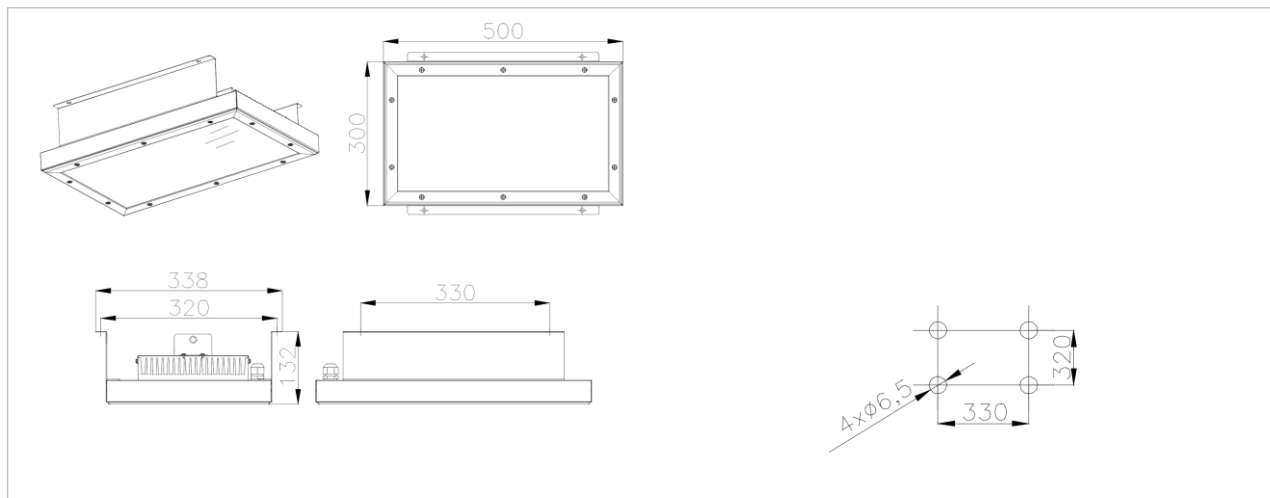

Product type	L (mm)	m (mm)	l (mm)	n (mm)	H (mm)
PREMIUM LUX 90 LED VISIBLE	500	330	338	320	132

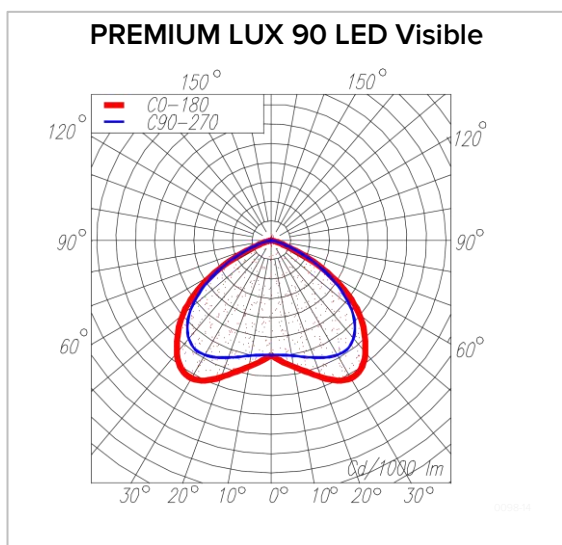

Photometric data PREMIUM LUX 90 LED

Light distribution diagram [Cd/1000lm]

Description

It is a modern luminaire with LED module.

- The projector has a simple, robust construction and it is easy to install and maintain.
- The body of the projector is made of steel sheet, in welded construction, painted with powder.
- Straps for mounting made of painted steel, which allow a fast and easy mounting.
- The construction of the projector stands out with the optical unit - mirrored aluminium sheet, LED modules, and with the gear unit (electrical gear (driver) included in the product and manufactured according to the specific standards).
- Frame made of extruded anodised aluminium frame that holds the glass diffuser.
- Thermo-secured glass that protects the optical compartment.
- The product has a thermic management system made of passive aluminium cooler to ensure the long lifetime.
- Connection box.
- Gear (electronic driver) included in the product and manufactured according to the specific standards.
- Colour: white.

Mounting

- The product has straps for mounting made of painted steel, that allow a fast and easy mounting
- Visible with screws or suspended on chain or rods. The mounting accessories are not included in the product.

Technical features

- Rated voltage: 230V/50Hz.
- Surrounding temperature: $-20^{\circ}\text{C} \div +35^{\circ}\text{C}$
- Relative humidity: 80% at the temperature of $+20^{\circ}\text{C}$.
- Jolt resistance: 1000 \pm 10 jolts, acceleration of 10g, duration of impulse: 16ms, according to SR EN 60068-2-29.
- The luminaire is manufactured according to requirements of the standards SR EN 60598-1, SR EN 60598-2-1.

Compliance with the European Directives

- Low Voltage Directive.
- Electromagnetic Compatibility Directive
- RoHS Directive, WEEE Directive

Product type	Product code	Rated voltage [V]	Rated power [W]	Power factor	Protection degree	Class of protection against electric shock	IK	Weight [Kg]	Total initial brut LEDs flux [lm]	Total luminous efficiency [lm/W]
PREMIUM LUX 90 LED A (6500K)	35317017	230	102	0.98	IP43	I	IK07	12.7	9234	91

A = Visible mounting

S.C. ELBA S.A improves continuously its products. We reserve the right to change the specifications in the interest of improving our products without prior notifications or public announcement. © S.C. ELBA S.A.